

M-824 Compact 6-Axis Vacuum Positioning System

Precision Parallel-Kinematics Micropositioner with Controller, Vacuum Versions

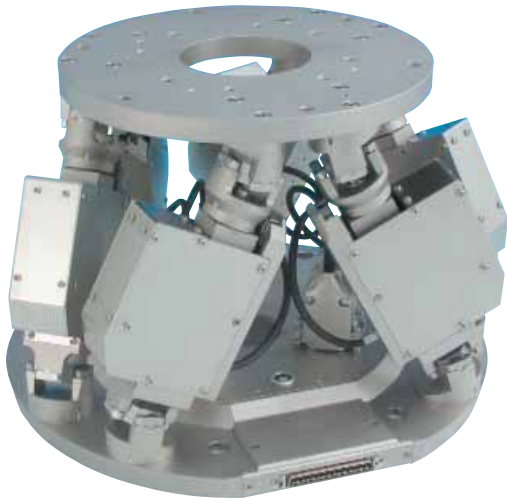

M-824.3DG compact vacuum Hexapod

- **Extremely Compact**
- **Travel Ranges to 45 mm (linear), 25° (rotation)**
- **Load Capacity to 10 kg, Self Locking Version**
- **Resolution to 7 nm**
- **Min. Incremental Motion to 300 nm**
- **Repeatability ±0.5 µm**
- **Velocity to 25 mm/sec**
- **Vacuum-Compatible Versions Available**

The M-824 is the ideal micro-positioning system for all complex positioning tasks which depend on high speed and accuracy in six independent axes. In addition to positioning all axes, it allows the user to define a center of rotation (pivot point) anywhere inside or outside the system envelope by one simple software command.

Application Examples

- **Biotechnology**
- **Semiconductor technology**
- **Micromachining**
- **Micromanipulation**
- **X-ray diffraction measurements**
- **Tool control**

Extremely Compact, Two Motor Versions

The M-824 uses a very compact drive with motor and spindle mounted side-by-side and, with a height of 188 mm, has a considerably lower profile than either the M-850, page 4-6, or M-840, page 4-8 Hexapods. Two versions featuring different drives are offered: the self-locking M-824.3DG with DC motor and gearhead can position loads of up to 5 kg in any orientation (10 kg with baseplate horizontal) with sub-micron precision. The M-824.3PD with integrated ActiveDrive™ system provides a significantly higher velocity of up to 25 mm/sec with loads up to 5 kg.

Hexapod vs. Serial Kinematics Systems

The Hexapod is driven by six high-resolution actuators all

connected directly to the same moving platform. This design provides a high system stiffness and a large clear aperture.

Because of the low mass of the moving platform, positioning operations can be performed with far lower settling times than with conventional, stacked multi-axis systems. In such systems, runout, guiding errors, and the friction and inertia of moving cables all accumulate to limit accuracy and repeatability—problems which do not affect parallel kinematic systems like the Hexapod.

Fixed Virtual Pivot Point

For optics and other alignment tasks, it is important to be able to define a fixed pivot point. The sophisticated Hexapod controller allows choosing any point in space as the pivot point for the rotation axes by

Ordering Information

- M-824.3VP**
Compact Hexapod Microrobot with Controller, Direct Drive, Vacuum Compatible to 10⁻⁶ hPa
- M-824.3VG**
Compact Hexapod Microrobot with Controller, DC Motor Gearhead, Vacuum Compatible to 10⁻⁶ hPa

software command. The pivot point remains fixed relative to the platform.

Target positions in 6-space are entered in user-friendly coordinates and reached by smooth vectorized motion.

Vacuum Versions

Both models are available as vacuum versions that enable use in applications such as X-ray diffraction microscopy with ambient pressures down to 10⁻⁶ hPa.

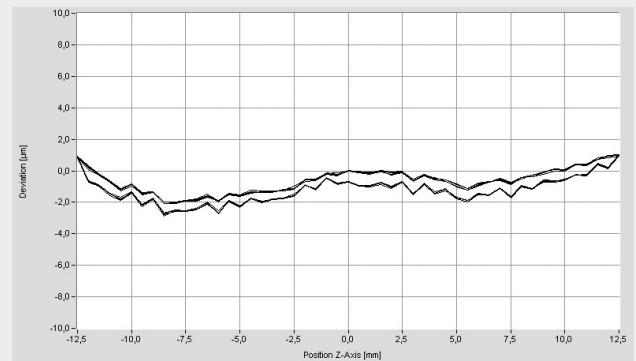

The interferometer test shows the Z axis accuracy over the entire travel range of 25 mm and the extremely high repeatability of ±0.046 µm



The M-824 comes with a powerful 6D controller and sophisticated, user-friendly positioning and alignment software. Keypad and display are optional

Open Architecture

Control of the hexapod is facilitated by the controller's open interface architecture, which provides a variety of high-level commands and includes a macro language for programming and storing command sequences.

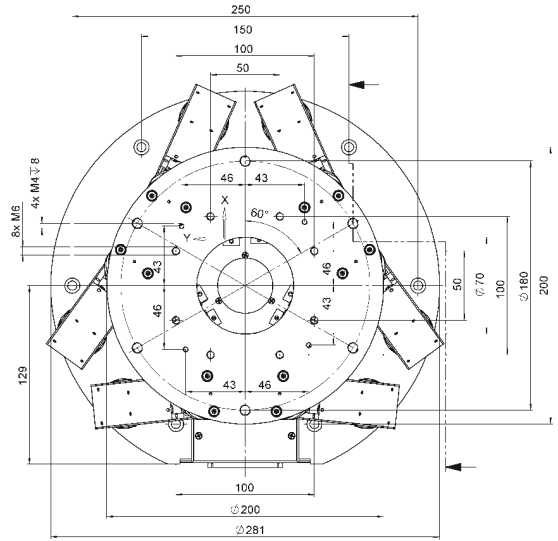
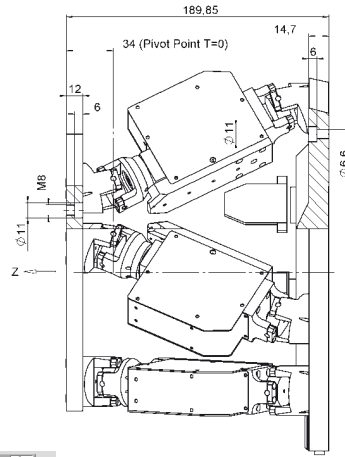

M-824 dimensions in mm, 3 m cable included

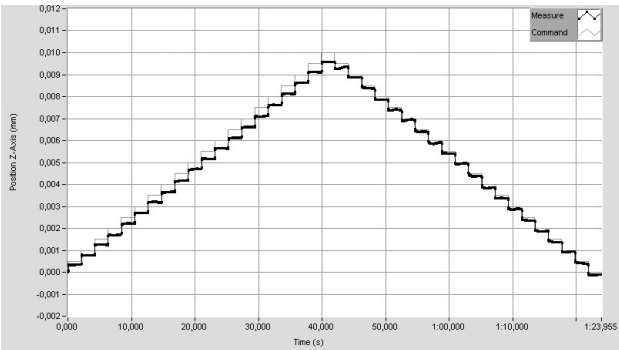

Interferometer tests show the high repeatability, here with 500 nm steps

Technical Data

Model	M-824.3DG	M-824.3PD	Units
Active axes	X, Y, Z, θ_x , θ_y , θ_z	X, Y, Z, θ_x , θ_y , θ_z	
Motion and positioning			
*Travel range X, Y	±22.5	±22.5	mm
*Travel range Z	±12.5	±12.5	mm
*Travel range θ_x , θ_y	±7.5	±7.5	°
*Travel range θ_z	±12.5	±12.5	°
Single-actuator drive	DC-motor, gearhead	ActiveDrive™ DC Motor	
Actuator stroke	±12.5	±12.5	mm
Single-actuator design resolution	0.007	0.5	µm
Integrated sensor	Rotary encoder	Rotary encoder	
Sensor resolution	2048	2048	cts./rev.
**Min. incremental motion X, Y, Z	0.3	1	µm
**Min. incremental motion θ_x , θ_y , θ_z	3.5	12	µrad
Repeatability X, Y, Z	±0.5	±0.5	µm
Repeatability θ_x , θ_y , θ_z	±6	±6	µrad
Max. velocity X, Y, Z	1	25	mm/s
Max. velocity θ_x , θ_y , θ_z	11	270	mrad/s
Typ. velocity X, Y, Z	0.5	10	mm/s
Typ. velocity θ_x , θ_y , θ_z	5.5	55	mrad/s
Mechanical properties			
*Stiffness X, Y	1.7	1.7	N/µm
Stiffness Z	7	7	N/µm
Load capacity (baseplate horizontal/any orientation)	10/5***	5/2.5	kg
Miscellaneous			
Operating temperature range	-10 to +50	-10 to +50	°C
Material	Aluminum	Aluminum	
Mass	8	8	kg
Controller			
Controller included	M-850.502	M-850.502	
Operating voltage	100–240 VAC, 50/60 Hz	100–240 VAC, 50/60 Hz	

*The travel ranges of the individual coordinates (X, Y, Z, θ_x , θ_y , θ_z) are interdependent. The data for each axis in this table shows its maximum travel, where all other axes are at their zero positions. If the other linear or rotational coordinates are not zero, the available travel may be less

**Simultaneous motion of all 6 actuators! No moving cables (as in serial-kinematics stacked systems) to introduce bending sources, torque and friction, which degrade positioning accuracy

***Self Locking

Technical data are specified at 20 ± 3 °C. Data for vacuum versions may differ.

M-850K Vacuum Hexapod 6-Axis Positioner

Parallel-Kinematics System for Wide Temperature Ranges



This custom hexapod was designed to work in a thermo-vacuum chamber

- 6 Degrees of Freedom, Works in Any Orientation
- Vacuum Compatible up to 10^{-6} hPa
- 200 kg Load Capacity (Vertical)
- Repeatability to $\pm 1 \mu\text{m}$
- Encoder Resolution to 5 nm

Model	Operating temperature range	Storage temperature	Travel ranges	Dimensions
M-850KTVH Vacuum Hexapod	-10 bis +25 °C	-20 bis +40 °C	± 50 mm (X,Y), ± 25 mm (Z), $\pm 15^\circ$ (θ_x, θ_y), $\pm 30^\circ$ (θ_z)	\varnothing 350 mm 330 mm height

M-811 Miniature Vacuum Hexapod

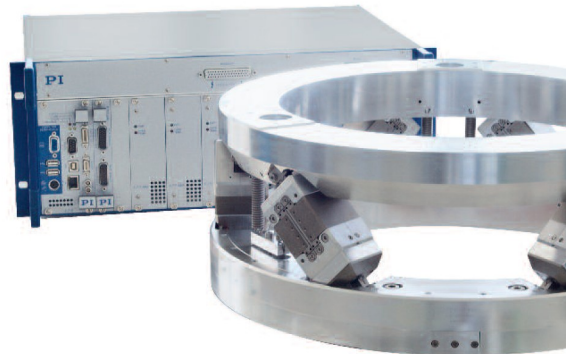

Custom piezo hexapod with controller

Custom Vacuum Hexapod

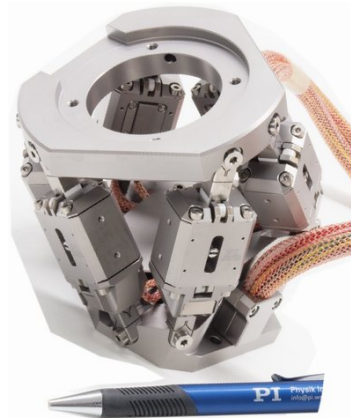
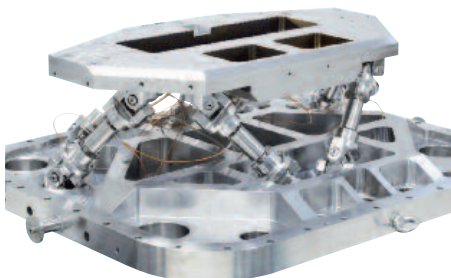

Custom miniature piezo hexapod

© Physik Instrumente (PI) GmbH & Co. KG 2008. Subject to change without notice. All data are superseded by any new release. The newest release for data sheets is available for download at www.pi.ws. RTVOr Cat120E Inspirations2009 08/10.18--110318-0

More Hexapods: <http://www.hexapods.net>



Program Overview

- Piezo Ceramic Actuators & Motors
- Piezo Nanopositioning Systems and Scanners
- Active Optics / Tip-Tilt Platforms
- Capacitive Nanometrology Sensors
- Piezo Electronics: Amplifiers and Controllers
- Hexapod 6-Axis Positioners / Robots
- Micropositioning Stages & Actuators
- Photonics Alignment Systems, Solutions for Telecommunications
- Motor Controllers
- Ultrasonic Linear Motors

Request or download the complete PI Nanopositioning & Piezo Actuator Catalog



USA (East) & CANADA

PI (Physik Instrumente) L.P.
16 Albert St.
Auburn, MA 01501
Tel: +1 (508) 832 3456
Fax: +1 (508) 832 0506
info@pi-usa.us
www.pi-usa.us

USA (West) & MEXICO

PI (Physik Instrumente) L.P.
5420 Trabuco Rd., Suite 100
Irvine, CA 92620
Tel: +1 (949) 679 9191
Fax: +1 (949) 679 9292
info@pi-usa.us
www.pi-usa.us

JAPAN

PI Japan Co., Ltd.
Akebono-cho 2-38-5
Tachikawa-shi
J-Tokyo 190
Tel: +81 (42) 526 7300
Fax: +81 (42) 526 7301
info@pi-japan.jp
www.pi-japan.jp

PI Japan Co., Ltd.
Hanahara Dai-ni Building, #703
4-11-27 Nishinakajima,
Yodogawa-ku, Osaka-shi
J-Osaka 532
Tel: +81 (6) 6304 5605
Fax: +81 (6) 6304 5606
info@pi-japan.jp
www.pi-japan.jp

CHINA

**Physik Instrumente
(PI Shanghai) Co., Ltd.**
Building No. 7-301
Longdong Avenue 3000
201203 Shanghai, China
Tel: +86 (21) 687 900 08
Fax: +86 (21) 687 900 98
info@pi-china.cn
www.pi-china.cn

UK & IRELAND

PI (Physik Instrumente) Ltd.
Trent House
University Way,
Cranfield Technology Park,
Cranfield,
Bedford MK43 0AN
Tel: +44 (1234) 756 360
Fax: +44 (1234) 756 369
uk@pi.ws
www.physikinstrumente.co.uk

FRANCE

PI France S.A.S
244 bis, avenue Max Dormoy
92120 Montrouge
Tel: +33 (1) 55 22 60 00
Fax: +33 (1) 41 48 56 62
info.france@pi.ws
www.pi-france.fr

ITALY

Physik Instrumente (PI) S.r.l.
Via G. Marconi, 28
I-20091 Bresso (MI)
Tel: +39 (02) 665 011 01
Fax: +39 (02) 873 859 16
info@pionline.it
www.pionline.it

GERMANY

**Physik Instrumente (PI)
GmbH & Co. KG**
Auf der Römerstr. 1
D-76228 Karlsruhe/Palmbach
Tel: +49 (721) 4846-0
Fax: +49 (721) 4846-100
info@pi.ws · www.pi.ws